

# LINC-NIRVANA – How to get a 23m wavefront nearly flat

Wolfgang Gässler<sup>a</sup>, Roberto Ragazzoni<sup>a,b</sup>, Tom M. Herbst<sup>a</sup>,  
D. Andersen<sup>a</sup>, C. Arcidiacono<sup>b</sup>, H. Baumeister<sup>a</sup>, U. Beckmann<sup>d</sup>,  
J. Behrend<sup>d</sup>, T. Bertram<sup>c</sup>, P. Bizenberger<sup>a</sup>, H. Böhnhardt<sup>a</sup>, F. Briegel<sup>a</sup>, E. Diolaiti<sup>b</sup>,  
T. Driebe<sup>d</sup>, A. Eckhardt<sup>c</sup>, Sebastian E. Egner<sup>a</sup>, J. Farinato<sup>b</sup>, M. Heininger<sup>d</sup>, M. Kürster<sup>a</sup>,  
W. Laun<sup>a</sup>, S. Ligori<sup>a</sup>, V. Naranjo<sup>a</sup>, E. Nußbaum<sup>d</sup>, H.-W. Rix<sup>a</sup>, R.-R. Rohloff<sup>a</sup>, P. Salinari<sup>b</sup>,  
R. Soci<sup>a</sup>, C. Storz<sup>a</sup>, C. Straubmeier<sup>c</sup>, E. Vernet-Viard<sup>b</sup>, G. Weigelt<sup>d</sup>, R. Weiss<sup>a</sup>, W. Xu<sup>a</sup>

<sup>a</sup>Max Planck Institut für Astronomie, Königstuhl 17, D-69117 Heidelberg, Germany

<sup>b</sup>Astronomical Observatory of Arcetri, Largo E. Fermi 5, I-50125 Firenze, Italy

<sup>c</sup>1. Physikalisches Instiut, Universität Köln, Zülpicher Strasse 77, D-50937 Köln, Germany

<sup>d</sup>Max Planck Institut für Radioastronomie, Auf dem Hügel 69, D-53121 Bonn, Germany

## ABSTRACT

On the way to the Extremely Large Telescopes (ELT) the Large Binocular Telescope (LBT) is an intermediate step. The two 8.4m mirrors create a masked aperture of 23m. LINC-NIRVANA is an instrument taking advantage of this opportunity. It will get, by means of Multi-Conjugated Adaptive Optics (MCAO), a moderate Strehl Ratio over a 2 arcmin field of view, which is used for Fizeau (imaging) interferometry in J,H and K. Several MCAO concepts, which are proposed for ELTs, will be proven with this instrument. Studies of sub-systems are done in the laboratory and the option to test them on sky are kept open. We will show the implementation of the MCAO concepts and control aspects of the instrument and present the road map to the final installation at LBT. Major milestones of LINC-NIRVANA, like preliminary design review or final design review are already done or in preparation. LINC-NIRVANA is one of the few MCAO instruments in the world which will see first light and go into operation within the next years.

**Keywords:** LBT, LINC-NIRVANA, Multi-Conjugate Adaptive Optics, Fizeau Interferometry

## 1. INTRODUCTION

The Large Binocular Telescope (LBT) is currently constructed at Mt. Graham, Arizona, USA, and will see first light soon.<sup>1</sup> The telescope consist of two 8.4m mirrors with a baseline of 14.4m which, combining them, can be used as a 22.8m diameter aperture masked telescope. The spatial resolution of a full 22.8m aperture in all directions can be reconstructed with observations of the same target at a minimum of three different parallactic angles with a distance of 60 degree each.<sup>2</sup> LINC-NIRVANA is a Fizeau (Imaging) interferometer which takes advantage of this opportunity.

As LBT is a ground based telescope there is need of Adaptive Optics to overcome the seeing introduced through the atmosphere<sup>3</sup> to exploit the diffraction limit of the telescope. LINC-NIRVANA is going even one step further, doing Multi-Conjugated Adaptive Optics (MCAO)<sup>4</sup> to get homogenous correction over the full science field but also to extend the sensitivity and the sky coverage for the measurement of the optical path difference with the Fringe and Flexure Tracker (FFT). The idea of MCAO is to correct the atmosphere with more than one deformable mirror (DM), each mirror conjugated to different altitudes correcting the turbulence at this height best. Turbulence in higher regions of the atmosphere has more impact on the isoplanatic patch than the one in lower altitude. Therefor the overall anisoplanatism is reduced over a larger field of view by correcting high layer turbulence in addition to the ground layer turbulence. There exist two different methods to do MCAO. One is the star oriented approach which senses each star separately and reconstructs from this information the

---

Further author information: (Send correspondence to W. Gaessler)

E-mail: gaessler@mpia.de, Telephone: +49 6221 528 395

turbulence distribution in the atmospheric volume sensed. The other is the layer oriented<sup>5</sup> approach which is trying to measure the turbulent layer best to which the DM is conjugated using the light of all stars together. Several mixed flavors of MCAO are proposed.<sup>6</sup> LINC-NIRVANA is using the layer oriented approach.

After a short overview of the instrument we will discuss the MCAO system in detail and finally explain the implementation phases we plan.

## 2. INSTRUMENT OVERVIEW

The LINC-NIRVANA instrument<sup>7</sup> is combining the right and left eye of the LBT over a science FoV of 10" x 10". The observation wavelength will be J, H, K. The IR Science Camera<sup>8</sup> is placed in the cryostat below the optical table (see Figure 1). The HAWAII2 chip from Rockwell with 2k x 2k pixels is chosen as science detector.

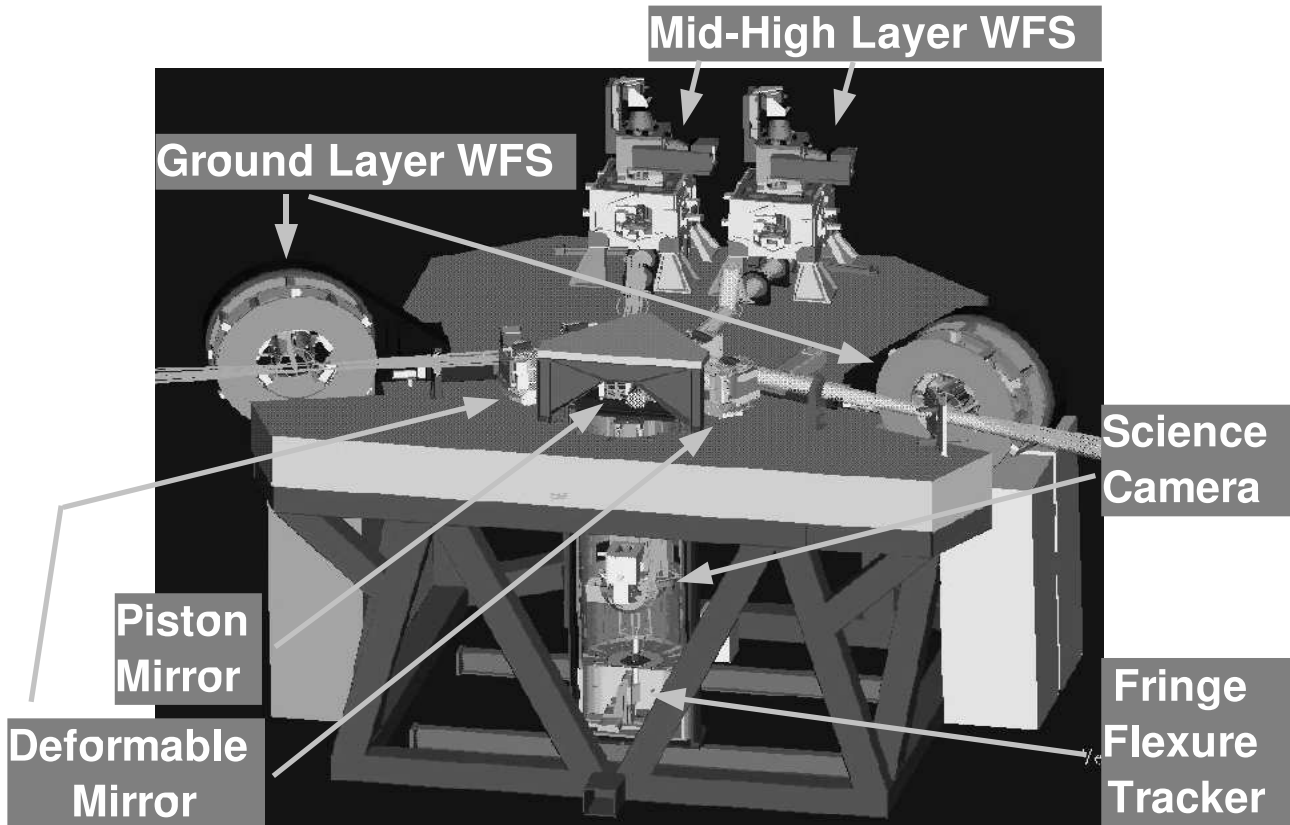
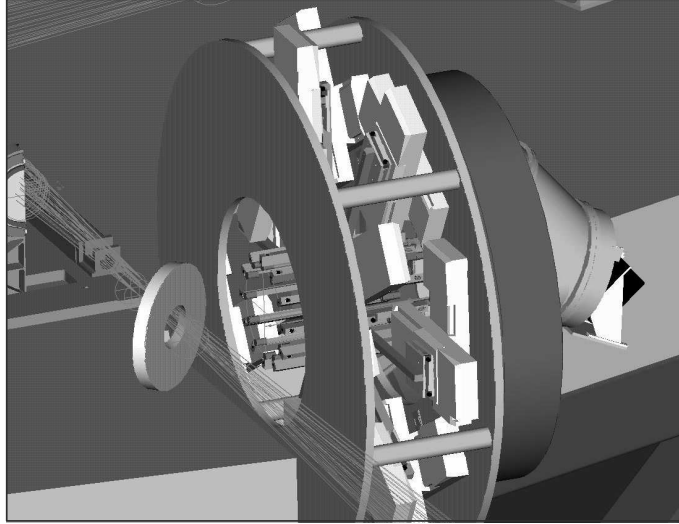

**Figure 1.** Overview of LINC-NIRVANA. All the major components are named. The overall dimensions of the instrument is about 3.5m x 6m x 2.5m (D x W x H).

The Fringe and Flexure Tracker (FFT)<sup>9</sup> is also placed in the near-infrared channel sharing the light with the science camera. A dichroic is dividing the light between the FFT and the science detector. The FFT sensor is driving a piston mirror correcting for optical path differences between the right and left arm.

The overall size of the bench is about 3.5m x 6m and the height is about 2.5m. The four wavefront sensors are placed on the top of the bench, one Ground Layer Wavefront Sensor (GWS) and one Mid-High Layer Wavefront Sensor (MHWS) for each side, left and right.

The GWS are driving the adaptive secondaries<sup>10</sup> of the telescope which are equipped with 672 voice coil actuators. The MHWS control piezo stack DM with 349 actuators. The DM are placed in a constant envelope collimator where the size of the meta-pupil is kept equal. Therefore it is possible to move the DM over the full length of the collimator illuminating always all actuators. No degree of freedom is lost for wavefront correction.



**Figure 2.** Ground Layer Wavefront Sensor (GWS). 12 star enlargers can pick up one guide star each out of the annular field. The light is optically co-added on the detector AT the back of the sensor. The full unit is de-rotated with a bearing.

The de-rotation of the instrument has to be done for each sub-system separately because of the geometry of the telescope and the position of the instrument in the front bent focus of the LBT. A common de-rotation of the full instrument is not possible because of different chirality of the beam from left and right side, which also destroys the homotheticity of the pupil if using i.e. different optical de-rotator for each arm.

### 3. MCAO WAVEFRONT SENSORS

MCAO has two major goals. The first goal is to get a **wider isoplanatic patch** in which the atmosphere is corrected. The second goal is to enlarge the field where guide stars can be chosen from aiming on a higher **sky coverage**. As it is quite expensive to cover a full 2' FoV with infrared detectors in proper sampling for a 23m class imager, LINC-NIRVANA is using MCAO, in its first, just to increase the sky coverage and the sensitivity for the FFT and AO guide stars.

Both sensors, GWS and MHWS, are testing novel techniques for wavefront sensing which are proposed in the perspective to be used later on Extremely Large Telescopes (ELT) with aperture diameters of 30 to 100 meters. Table 1 contains the main feature of the wavefront sensors.

GWS	MHWS
Pyramid Wavefront Sensor	
Optical co-adding	
12 NGS	8 NGS
Multiple Field of View	
2'- 6' diameter annular ring	2' diameter central circle
sensing wavelength: 0.6-0.9 $\mu\text{m}$	

**Table 1.** Overview of the wavefront sensor features.

The GWS (Figure 2) is fed directly with the F/15 telescope focus through an annular fold mirror. Up to 12

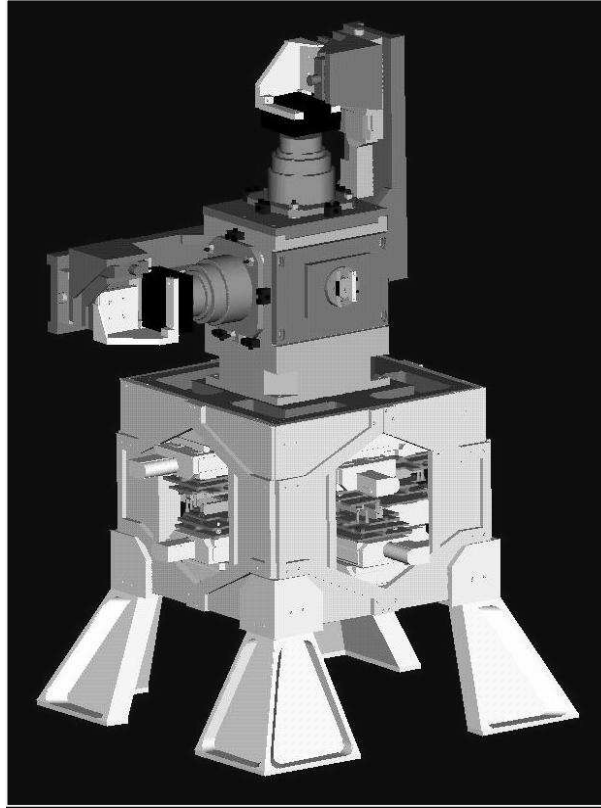

**Figure 3.** Mid-High Layer Wavefront Sensor (MHWS). 8 star enlarger can pick up a natural guide star (NGS) out of the center 2' FoV. The light is optically co-added on the detector. De-rotation is done with a K-mirror in the F/20 camera which is feeding the sensor with light. The light is split between mid and high layer.

star enlarger, on two cross mounted translation stages, can pick up a guide star out of the annular field with 2' inner and 6' outer diameter. The star enlargers were proposed by Ragazzoni et al.<sup>11</sup> to overcome problems in dimensions when re-imaging the four pupils created by the Pyramid Sensor<sup>12</sup> while keeping the spot on the tip of the pyramid large. Each star enlarger has its own pyramid. The pupils of all the stars are optically co-added on one detector. Such technique is applicable with any pupil wavefront sensors like the Pyramid Sensor or the Curvature Sensor. The complete GWS unit is de-rotated with a bearing. Therefore the star enlarger don't need further movement after positioning until a new target gets acquired.

The MHWS (Figure 3) is fed with visible light through a F/20 camera. 8 star enlargers are used to pick up guide stars in the central 2'. The sensor uses also optical co-adding. The de-rotation is done optically with a K-mirror placed in the F/20 camera. The light is split between the mid and the high layer. The mid layer can be conjugated to 4-8 km while the high layer can be conjugated to 10-15 km. The ability to change the conjugated altitude is quite useful. There is not only a non negligible change in distance by larger zenith angles but just recently it was shown that turbulent layer show strong seasonal variations.<sup>13</sup> Table 2 gives an idea how the distance of a layer at an fixed altitude of 4km and 10km above the telescope changes.

The optical co-adding does allow to choose guides stars down to 20mag as long the integrated guide star is reaching values between 14-17mag. Such faint magnitudes and the large size for the FoV leads to a sky coverage of about 10% and 30% at the south galactic pole and the north galactic pole, respectively.<sup>14</sup> At galactic latitude the system will have a sky coverage above 90%.

The local de-rotation of the wavefront sensors requires to off-load continuously the current mapping between the sub-apertures on the CCD and the actuators of the DM. To simplify this procedure it is important to know

Zenith distance	layer 4km above telescope	layer 10km above telescope
30°	4.6km	11.5km
45°	5.6km	14.1km
60°	8km	20km

**Table 2.** Distance between a layer of a certain altitude and the telescope depending on the zenith distance. The altitude of the layer are chosen from turbulence measurements above San Pedro Mártir<sup>13</sup>

the linearity of the influence function of each actuator and its change with different temperature or gravity vector. Extensive tests with the 349 piezo stack actuator DM are already done and further are under way<sup>15</sup> to understand its behavior and using this knowledge to minimize initial day calibrations and re-calibrations during night.

#### 4. CONTROL SYSTEM

The instrument has five sub-systems driving mirrors with one or several hundred actuators to correct the shape of the incoming wavefront.

- Ground Layer Wavefront Sensors (GWS), right and left, controlling each an adaptive secondary (M2) with 672 actuators.
- Mid-High Layer Wavefront Sensors (MHWS), right and left, controlling each a piezo stack mirror with 349 actuators (DM).
- Fringe-Flexure Tracker Sensor (FFTS), controlling the piston mirror (Piston) with one actuator.

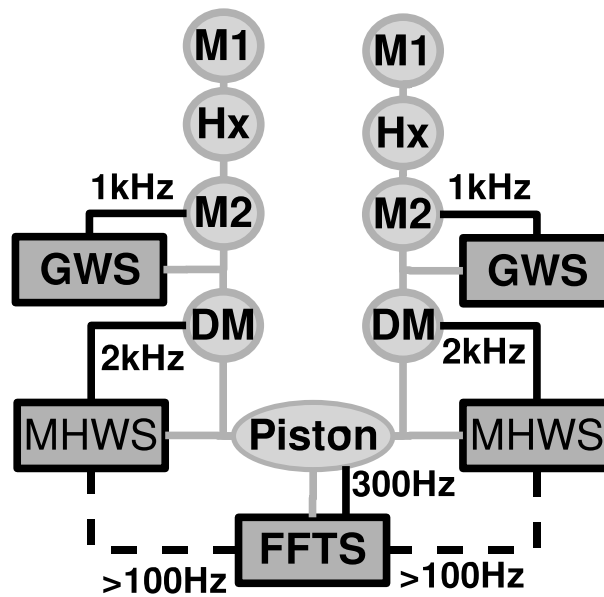

**Figure 4.** A simple control approach with loops in a cascade. The GWS does reduce the wavefront distortion with the adaptive secondary after that, optically decoupled, the MHWS does further wavefront improvement. The optical path difference corrected by the FFTS introduces piston which is not sensed with the MHWS and therefore does not affect the AO loop.

The MHWS itself consist out of two nested loop which we in approximation now treat as one. This is also supported from the fact, that in a first implementation we will have only the high layer DM for each side while the mid layer DM will be substituted with a flat mirror. If we reduce the system to the simplest control possible we have five independent loops as shown in Figure 4. This is feasible because there is no optical coupling of the sensors. GWS and MHWS are in cascade. The GWS loop will correct atmospheric perturbation but does not see the correction done by the MHWS. The MHWS is after the GWS and will see an already improved wavefront similar to an AO system running under good seeing conditions. There is no need of any interaction between the MHWS and GWS in the control. Both loops are robust running on its own.

The FFT only corrects for the optical path differences between right and left side. The piston introduced through the FFT is not visible to a Pyramid sensor and does therefor not influence the MHWS even the piston mirror is in its light path.

The sample frequency is 1kHz for the GWS and up to 2kHz for the MHWS, as higher wind speed is expected in higher altitudes. The FFTS has a sample frequency of 300Hz. Offloading of fast piston to the DM with a frequence larger than 100Hz and amplitudes smaller than  $1\mu\text{m}$  is thought of. This could become necessary because the piston mirror shows mechanical resonances at around 100Hz.

The GWS uses a CCD50 with  $128 \times 128$  pixel while the MHWS uses a CCD39 with  $80 \times 80$  pixels. Both CCDs are from E2V and driven with controller from SciMeasure. The FFTS detector will be a HAWAII1 1024 x 1024 pixels from Rockwell driven with the MPIA-in-house electronics. Only windows smaller than  $64 \times 64$  pixels will be read out for fringe tracking to get the required frame rate. The control computer will be a LINUX based PC, one computer for each loop.

To improve the overall system performance we plan for a data handling system (DHS) which will take care of modal gains and off-loading between the loops and to the telescope control system (TCS). Distortions from one layer are seen de-focused in the other layer. An extended control matrix taking care of such modes or a filter in the gain calculation could do some mediation between the loops to suppress over correction.

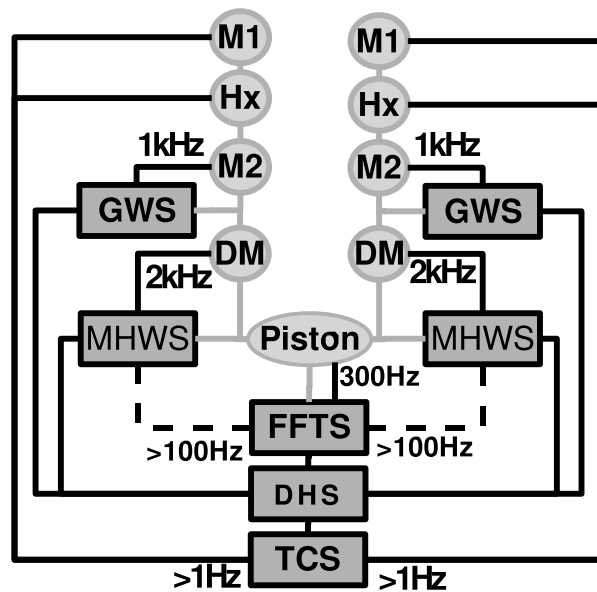

**Figure 5.** Extended control approach. A data handling system (DHS) is implemented to improve the performance. It will mediate through gain filtering and off loading between the single loops and the telescope control system (TCS).

## 5. IMPLEMENTATION PHASES

LINC-NIRVANA is a complex instrument using several novel and not finally proven techniques. We already studied and simulated the instrument and its sub-systems, like MCAO, FFTS, etc. up to a Preliminary Design level.<sup>16</sup> Several prototypes and experiments to prove concepts are done or under way. I.e. we are planning a single arm experiment with one MHWS and two DM in the laboratory with the option to test it also on sky<sup>15</sup> and with a further laboratory experiment we already tested the beam combination and FFT algorithms.<sup>17</sup> The installation of the instrument at LBT is split into three implementation steps:

- interferometry with single guide star AO
- single arm MCAO with 2 and 3 DM
- implementation of full MCAO (2 DM per arm first) with interferometry

Such breakdown of the instrument installation should help to understand each sub-system best to improve its performance.

## 6. CONCLUSIONS

LINC-NIRVANA is a Fizeau interferometer for the LBT using MCAO to increase the sky coverage. The MCAO provides a moderate strehl ratio over 2' FoV using the layer oriented approach. Through optical decoupling of all the wavefront sensors a very simple control approach can be used and complexity can be reduced. Similar subsystems with same hardware and software make maintenance easier. The instrument will be implemented at the telescope in three major steps to understand problems introduced by each component better and improve its performance. LINC-NIRVANA will be the first instrument making use of the 23m resolution at LBT over a wider field of view .

## Acknowledgment

The work is partially funded by the Alexander von Humboldt Foundation through the Wolfgang Paul Prize.

## REFERENCES

1. J. M. Hill and P. Salinari, "Large Binocular Telescope project," **5489**, SPIE, June 2004.
2. M. Carillet, S. Correia, P. Boccacci, and M. Bertero, "Restoration of interferometric images. II. The case-study of the Large Binocular Telescope," *A&A* **387**, p. 744, 2002.
3. H. W. Babcock, "The Possibility of Compensating Astronomical Seeing," *PASP* **65**, p. 229, 1953.
4. J. M. Beckers, "Increasing the Size of the Isoplanatic Patch with Multiconjugate Adaptive Optics," *Proceedings on ESO Conference on Very Large Telescopes and their Instrumentation*, p. 693, ESO, 1988.
5. R. Ragazzoni, "Adaptive optics for giant telescopes: NGS vs. LGS," *Backaskog workshop on extremely large telescopes* **57**, p. 175, ESO, 2000.
6. D. Bello *et al.*, "Numerical versus optical layer oriented: a comparison in terms of SNR," *Adaptive Optical System Technologies II* **4839**, p. 612, SPIE, 2003.
7. T. M. Herbst *et al.*, "The LINC-NIRVANA interferometric imager for the Large Binocular Telescope," **5492**, SPIE, June 2004.
8. P. Bizenberger, D. Andersen, H. Baumeister, U. Beckmann, E. Diolaiti, T. Herbst, W. Laun, L. Mohr, and C. Straubmeier, "The LINC-NIRVANA Cryogenic Interferometric Camera," **5490**, SPIE, June 2004.
9. C. Straubmaier *et al.*, "A fringe and flexure tracker system for LINC-NIRVANA: basic design and principle of operation," **5491**, SPIE, June 2004.
10. A. Riccardi, G. Brusa, P. Salinari, D. Gallieni, R. Biasi, *et al.*, "Adaptive secondary mirror for the Large Binocular Telescope," **4839**, p. 721, SPIE, 2003.
11. R. Ragazzoni, E. Diolaiti, E. Vernet-Viard, J. Farinato, and E. Marchetti, "Arbitrarily small pupils in layer-oriented Multi-Conjugate Adaptive Optics," *PASP*, accepted.

12. R. Ragazzoni, "Pupil plane wavefront sensing with an oscillating prism," *J. Mod. Opt.* **43**, p. 289, 1996.
13. E. Masciadri and S. Egner, "First complete seasonal variation study of the 3D optical turbulence above San Pedro Martir Observatory," **5490**, SPIE, June 2004.
14. C. Arcidiacono *et al.*, "Sky coverage for layer oriented MACAO: a detailed analytical and numerical study," **5490**, SPIE, June 2004.
15. S. Egner *et al.*, "LINC-NIRVANA: the single arm MCAO experiment," **5490**, SPIE, June 2004.
16. *Preliminary Design Review of LINC-NIRVANA*, 2003. available at [www.mpia.de/LINC/Files/PDR.pdf](http://www.mpia.de/LINC/Files/PDR.pdf).
17. D. R. Andersen, S. Egner, T. M. Herbst, C. Straubmeier, and T. Bertram, "LINC-NIRVANA testbed Fizeau interferometer," **5490**, SPIE, June 2004.