

The MCAO wavefront sensing system of LINC-NIRVANA: status report

Jacopo Farinato^{*a}, Roberto Ragazzoni^a, Carmelo Arcidiacono^a, Gentile Giorgia^a, Emiliano Diolaiti^b, Italo Foppiani^b, Matteo Lombini^b, Laura Schreiber^b, Dario Lorenzetti^c, Francesco D'Alessio^c, Gianluca Li Causi^c, Fernando Pedichini^c, Fabrizio Vitali^c, Tom Herbst^d, Martin Kürster^d, Peter Bizenberger^d, Florian Briegel^d, Fulvio De Bonis^d, Sebastian Egner^d, Wolfgang Gässler^d, Lars Mohr^d, Alexei Pavlov^d, Ralf Rainer Rohloff^d, Roberto Soci^d

^aINAF – Osservatorio Astrofisico di Arcetri, Largo E. Fermi 5, I-50125 Firenze, Italy;

^bINAF – Osservatorio Astronomico di Bologna, via Ranzani 1, I-40127 Bologna, Italy;

^cINAF – Osservatorio Astronomico di Roma, Monte Porzio Catone, I-00040, Roma, Italy;

^dMax Planck Institute für Astronomie, Königstuhl 17, D-69117 Heidelberg, Germany;

ABSTRACT

LINC-NIRVANA is an infrared camera that will work in Fizeau interferometric way at the Large Binocular Telescope (LBT). The two beams that will be combined in the camera are corrected by an MCAO system, aiming to cancel the turbulence in a scientific field of view of 2 arcminutes. The MCAO wavefront sensors will be two for each arm, with the task to sense the atmosphere at two different altitudes (the ground one and a second height variable between a few kilometers and a maximum of 15 kilometers). The first wavefront sensor, namely the Ground layer Wavefront sensor (GWS), will drive the secondary adaptive mirror of LBT, while the second wavefront sensor, namely the Mid High layer Wavefront Sensor (MHWS) will drive a commercial deformable mirror which will also have the possibility to be conjugated to the same altitude of the correspondent wavefront sensor. The entire system is of course duplicated for the two telescopes, and is based on the Multiple Field of View (MFoV) Layer Oriented (LO) technique, having thus different FoV to select the suitable references for the two wavefront sensor: the GWS will use the light of an annular field of view from 2 to 6 arcminutes, while the MHWS will use the central 2 arcminutes part of the FoV. After LINC-NIRVANA has accomplished the final design review, we describe the MFoV wavefront sensing system together with its current status.

Keywords: Multi Conjugate Adaptive Optics, Layer Oriented, Fizeau Interferometry

1. INTRODUCTION

LINC-NIRVANA is an instrument for the Large Binocular Telescope (LBT), located in Mount Graham, Arizona. It will be an interferometric infrared camera, taking advantage of the full resolving power of the telescope baseline (22.8m) also due to the presence of two MCAO systems, one for each arm, that will provide a 2' corrected or partially corrected FoV. In the last years the proposed idea^{1,2} of compensating the atmosphere increasing the number of references used by the wavefront sensor and the number of deformable mirrors to perform the correction with the purpose to increase the corrected field of view of an instrument (namely Multi Conjugate Adaptive Optics - MCAO) has taken more and more importance, and a number of ideas, lab demonstrators³, on-sky demonstrators^{4,5} and real instruments^{6,7} are under construction in order to improve this technique and to take full advantage of it. Concerning the new ideas, the Layer-Oriented (L-O) one^{8,9} seems to be promising because of the efficient usage of light performed by this technique, and in the last years several improvements to this technique have been proposed in order to take advantage of its unique features, like the optical co-addition of the light at the level of the detectors, the usage of the Pyramid Sensor (PS)¹⁰ (which is more sensitive and thus more efficient than other conventional wavefront sensors like the Shack-Hartmann and the Curvature one¹¹) and the independency of the loops driving the deformable mirrors of the system. The Multiple Field of View (MFoV) technique is an improvement of the L-O technique, considering to use a wider FoV for the wavefront sensor conjugated to the ground in order to have higher probability to find suitable references. In this article, after

* farinato@pd.astro.it; phone: +39 049 8293474; fax: +39 049 8759840

recalling the basic principles of the L-O and MFOV techniques, we describe the status of the MCAO wavefront sensors for LINC-NIRVANA, being Istituto Nazionale per l'AstroFisica (INAF) responsible of their design and construction through four observatories (Padova, Arcetri, Bologna and Rome), with the co-operation of the Max Planck Institute für Astronomie in Heidelberg.

2. LAYER ORIENTED AND MULTIPLE FIELD OF VIEW

Just to recall the very basic concept of the L-O technique, the idea is to have the wavefront sensors which are looking to a certain number of stars simultaneously, and the light coming from all these references is optically super-imposed at the level of the detectors, where an image of the telescope entrance pupil is formed. To perform this operation one needs of course to use pupil plane wavefront sensors, like the pyramid or the curvature ones.

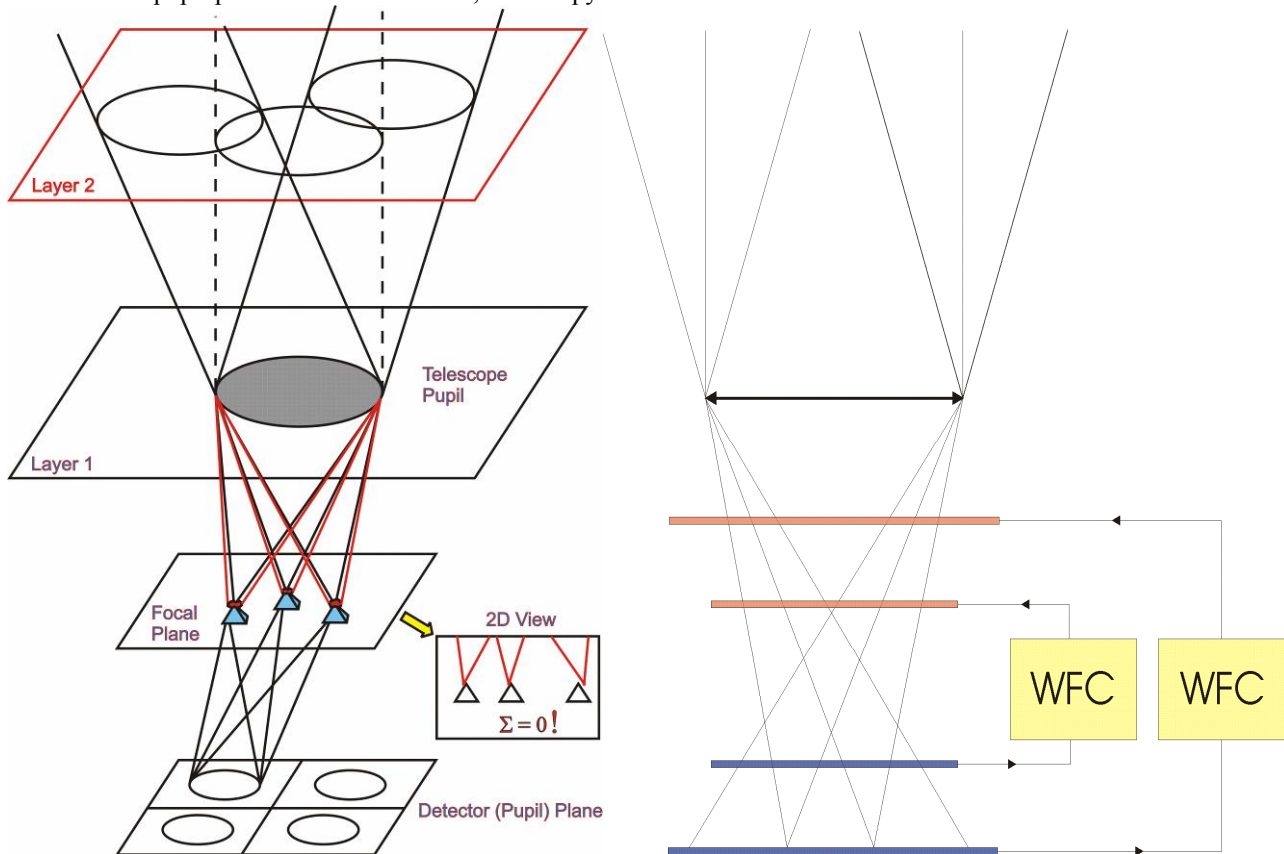

Figure 1: LEFT: the optical co-addition of the light in the L-O technique; RIGHT: the independency of the loops driving the deformable mirrors.

In Figure 1 left side it is shown the optical co-addition of the light in the case of the Pyramid Sensor use, from which it should be clear the advantage in term of Signal to Noise Ratio (SNR) compared to the classical Star Oriented MCAO, where each detector is looking at a single star.

Another interesting feature of the L-O is that each detector is conjugated to a DM, and each couple detector-DM is conjugated to a certain altitude chosen in order to minimize the residual atmospheric turbulence. Normally, being the ground layer quite strong and located very close to the telescope entrance pupil, in a system with 2 DMs one “couple” detector-DM is conjugated to the ground and the second one is conjugated to an intermediate altitude (between 5 and 10 kilometers) close to other powerful turbulent layers. The 2 loops are in fact totally independent from a computational point of view (see Figure 1 right side), thus simplifying the system in term of required computational power. But the main advantage is that each loop can be tuned in a way to mimic the behavior of the atmosphere at that altitude, meaning that the spatial and temporal sampling performed by the wavefront sensors can be optimized with respect to the relative

value of r_0 of that altitude, and this fact can bring a huge advantage in term of photons. There are a couple of draw-backs of the L-O technique, like the usage of relatively large detectors and the splitting of the light between the two wavefront sensors.

An evolution of the L-O is called the Multiple Field of View technique, where the idea behind is to use a larger FoV for the detector conjugated to the ground, in a way to increase the probability to find suitable references for the WFS. The loops remain independent and the light is still optically co-added at the level of the detector, so it is basically the L-O technique but with the WFSs which are using different fields of view. In Figure 2 there is a drawing which is explaining the MFoV approach, where the considered FoV of the 2 wavefront sensors are $2'$ and $6'$.

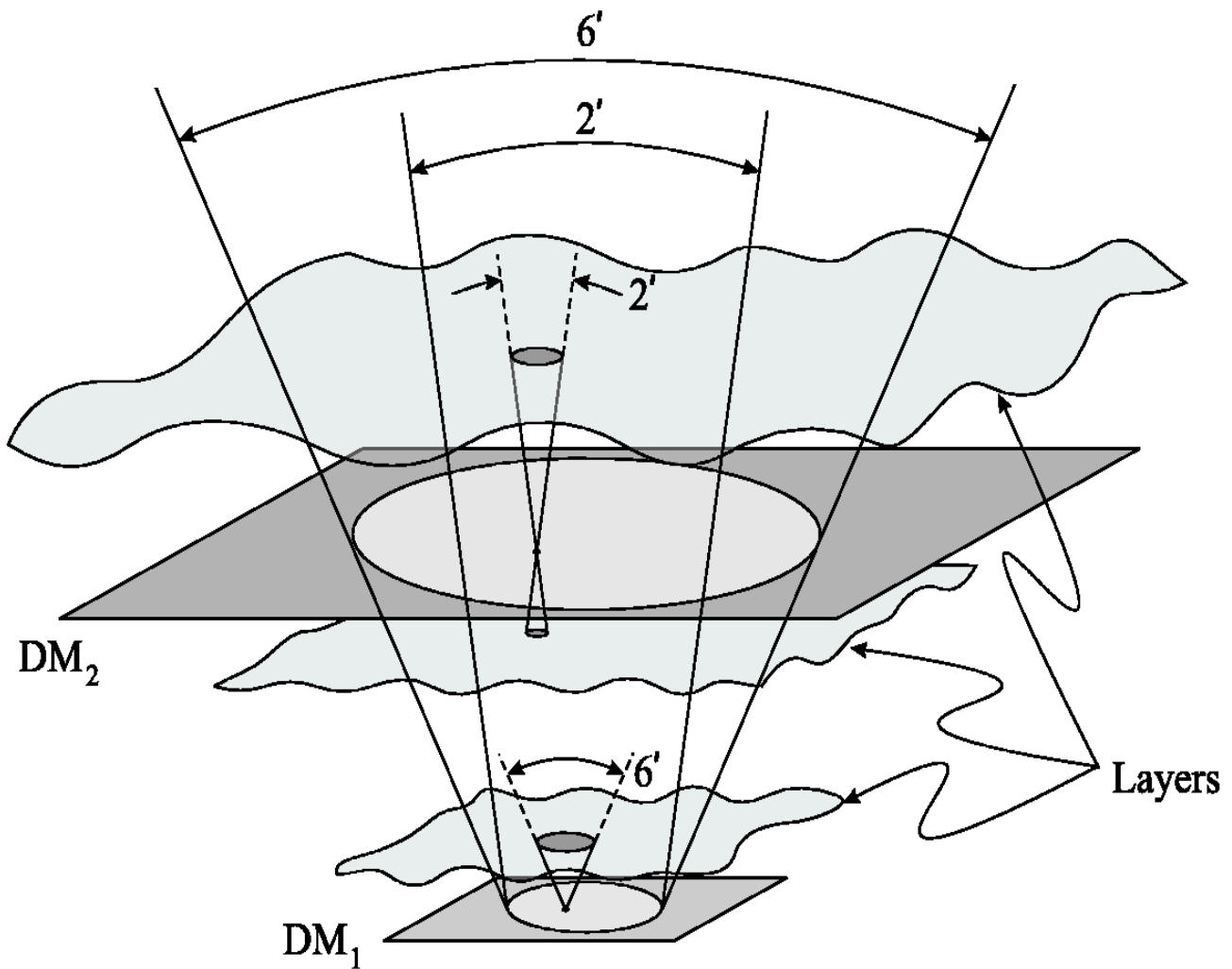

Figure 2: the Multiple Field of View Layer-Oriented technique.

Being the $6'$ FoV larger in surface of about 6 times than the $2'$, the internal FoV is used entirely by the high layer WFS while the ground one is using the annular FoV from $2'$ to $6'$. In this way, there is no need of light splitting between the 2 detectors, and thus there is an improvement in term of photons of about a factor 2 on the high layer WFS and of a factor 10 in the ground one when compared to the normal L-O approach!

Indeed, we should notice that increasing the FoV of the ground WFS means to decrease its depth of focus, meaning that this technique is working only in those observing sites where the ground turbulence is confined in a thin layer located very close to the ground, which is true for most of the observing sites.

It is clear anyway that, ideally, we should have a way to increase the FoV of a WFS maintaining its capability to be sensitive also to turbulent layers located not only very close to its conjugated altitude, and in the following section we show that this possibility exists.

3. THE LINC-NIRVANA MCAO SYSTEM

The LINC-NIRVANA instrument will have two MCAO systems, one for each arm, that will provide a corrected FoV of 2' to the LINC camera and to the fringe tracker. Each arm has two wavefront sensors, which are described in the following sections, together with the patrol camera, a system which allow the star selection for the MCAO.

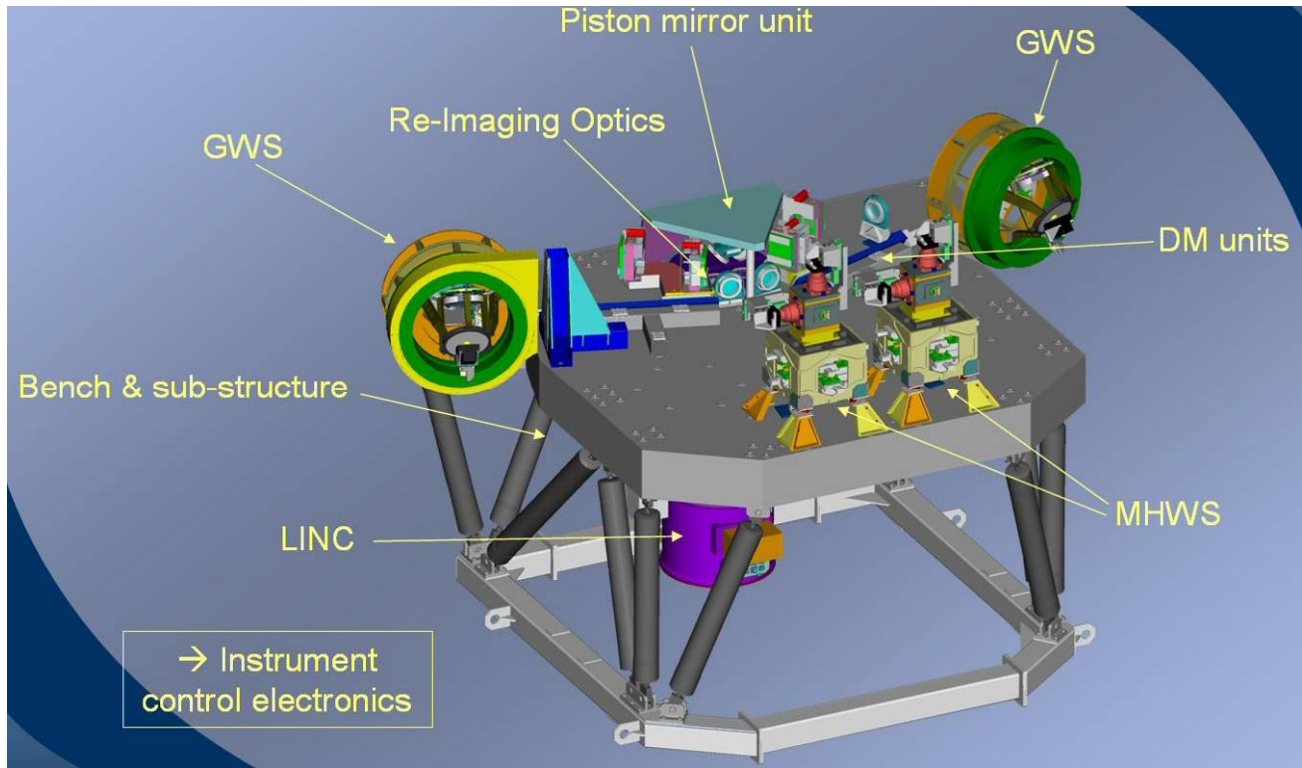

Figure 3: The LINC-NIRVANA optical bench

In Figure 3 there is an 3-D drawing of the LINC-NIRVANA optical bench, where all the major components are shown.

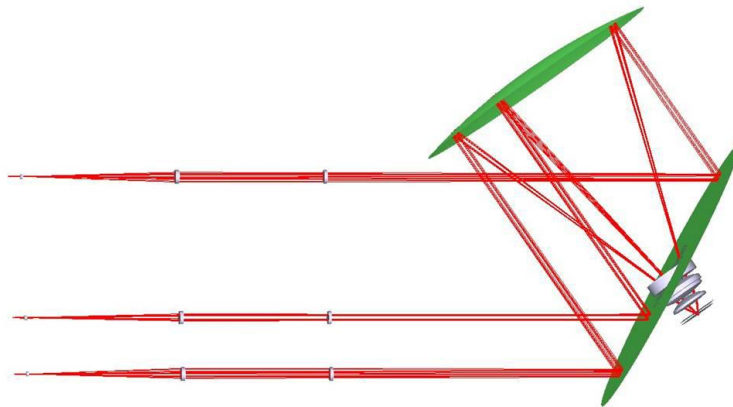

Figure 4: The GWS Optical Design

3.1. THE GROUND LAYER WAVEFRONT SENSOR

The GWS is conjugated to the ground, and it is using the FoV from 2' to 6' in diameter; the light is folded toward the WFS with an annular mirror, which let the central 2' pass through. A maximum of twelve pyramids can be placed in the FoV in order to pick-up a correspondent number of references to be used by the GWS for the wavefront sensing operations. The GWS is driving the Adaptive Secondary mirror (672 actuators) of the telescope in order to exploit the correction; a pupil re-imager is then creating 4 images of the pupils on the detector. The pupil re-imager is realized by using a hybrid configuration of mirrors and lenses, as it is shown in Figure 4: a first flat mirror (adjustable in tip-tilt) is folding the beam toward a parabolic mirror (adjustable in tip-tilt and centering), which is focusing the beam into a 4 lenses objective (also adjustable in tip-tilt and centering) that finally creates the four pupil images on the detector (adjustable in tip-tilt and centering). The CCD used for the GWS is a 128x128pixel detector.

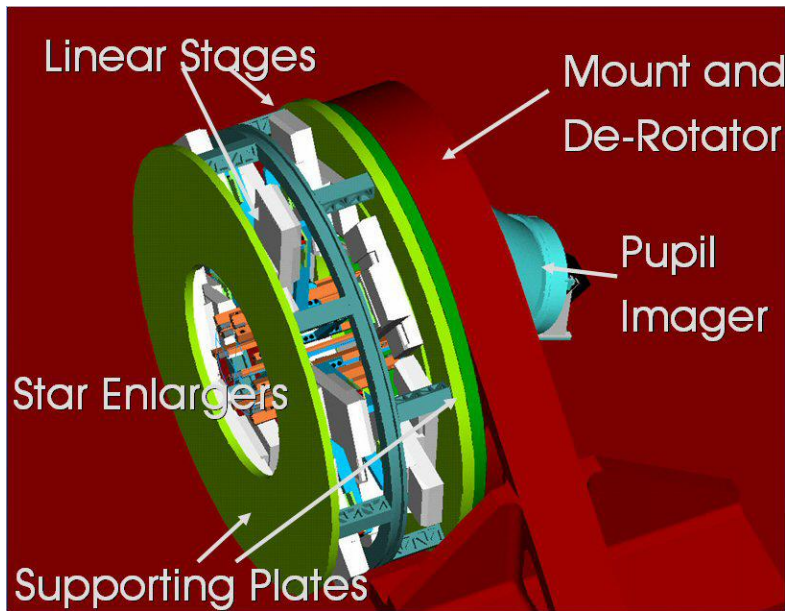

Figure 5: the Ground Layer wavefront sensor

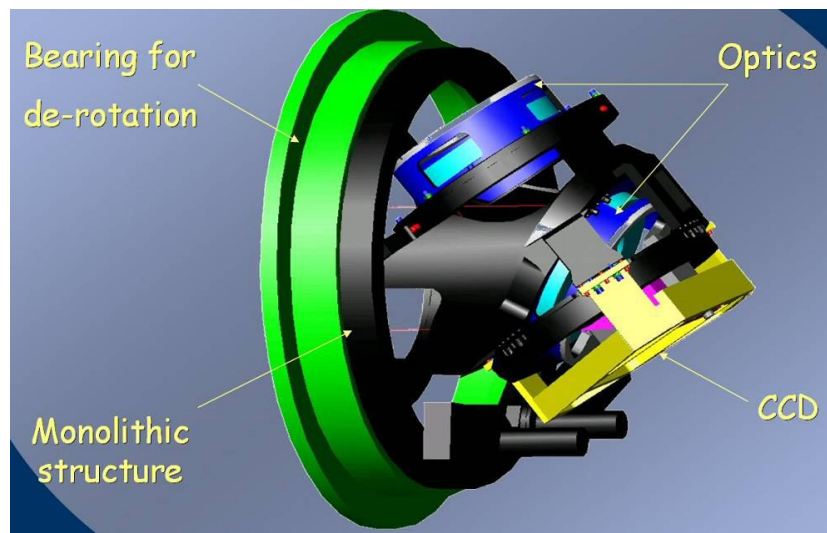

Figure 6: The pupil re-imager of the GWS

The status of the GWS, which will be integrated and tested in the astronomical observatory of Padova, is that the call for tender for all the optical elements have been issued, while in the immediate future the mechanics and the linear stages are going to be bought. The first system should be ready by mid 2007. In Figure 5 the GWS mechanical structure is shown, while in Figure 6 the hybrid pupil re-imager is shown.

3.2. THE MID-HIGH LAYER WAVEFRONT SENSOR

The MHWS is instead conjugated to an altitude that can vary from 4 to 15 Km, in order to optimize its correction, which is actuated from a Xinetics Deformable Mirror (DM), based on 349 piezo-stack actuators which is mounted on-board the optical bench. Following the L-O scheme, the DM has to be conjugated to the same altitude to which the WFS is conjugated. The MHWS is using the visible part of the central 2' FoV, and a maximum of eight pyramids can be positioned in such a FoV in order to select the suitable references for the wavefront sensor. The light is then sent to a 6 lenses pupil re-imager which creates four pupil images on the detector, an 80x80pixel CCD.

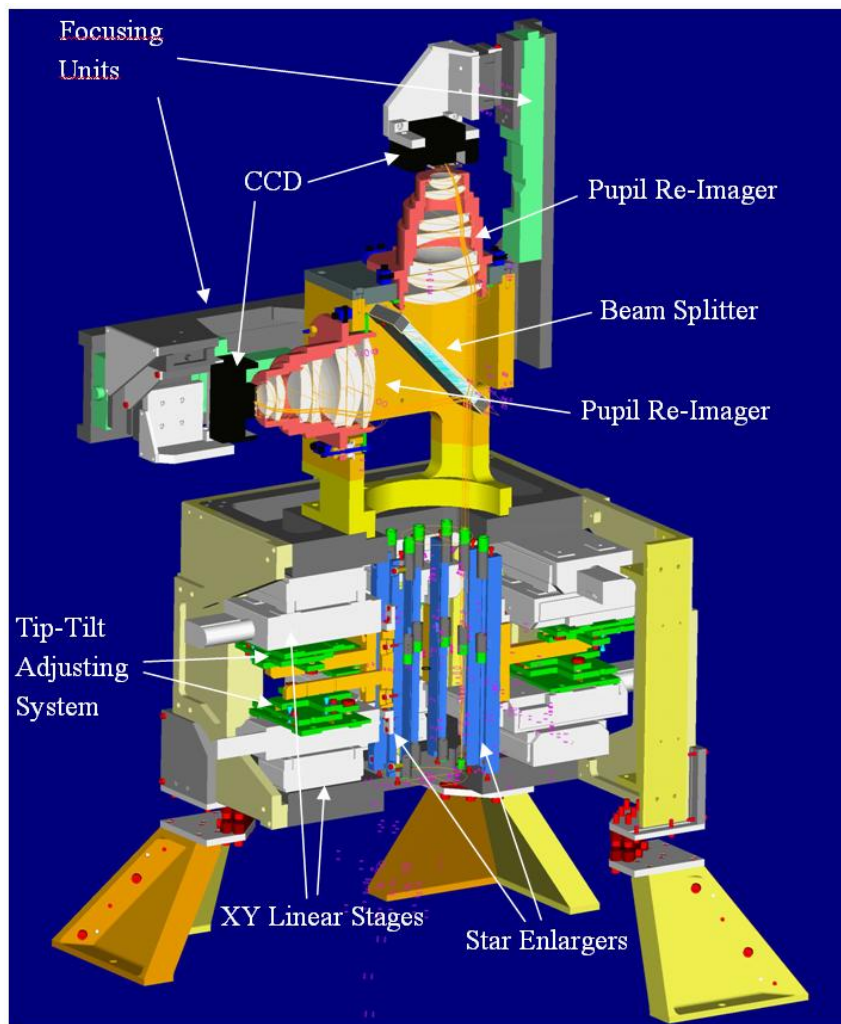

Figure 7: the Mid High Wavefront Sensor

The MHWS is in its integration phase in the astronomical observatory of Bologna, being optics, mechanics and positioning stages already delivered. In Figure 7 the various parts of the wavefront sensor are shown, while in Figure 8 two testing phases are presented. The first MHWS should be ready by the end of 2006.

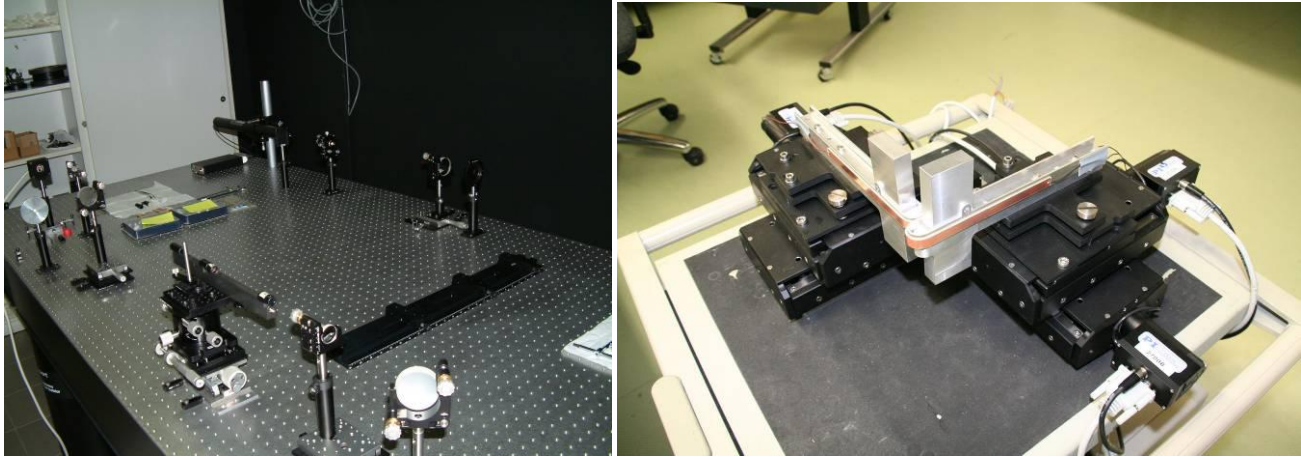

Figure 8: on the left side the setup used in Bologna Observatory to test and align the star enlargers, while on the right side the star enlargers collision tests performed in Heidelberg.

3.3. THE PATROL CAMERA

The patrol camera has the purpose to image the FoV of the MHWS in order to select a maximum of eight suitable references for the MHWS, and to position the correspondent star enlargers on the selected stars. A linear stage allow either to insert a beam splitter in the optical path of the light directed to the MHWS, dividing the light between the patrol camera and the MHWS during the selection phase, or to insert a folding mirror, sending the whole light to the MHWS during the normal operations of wavefront sensing.

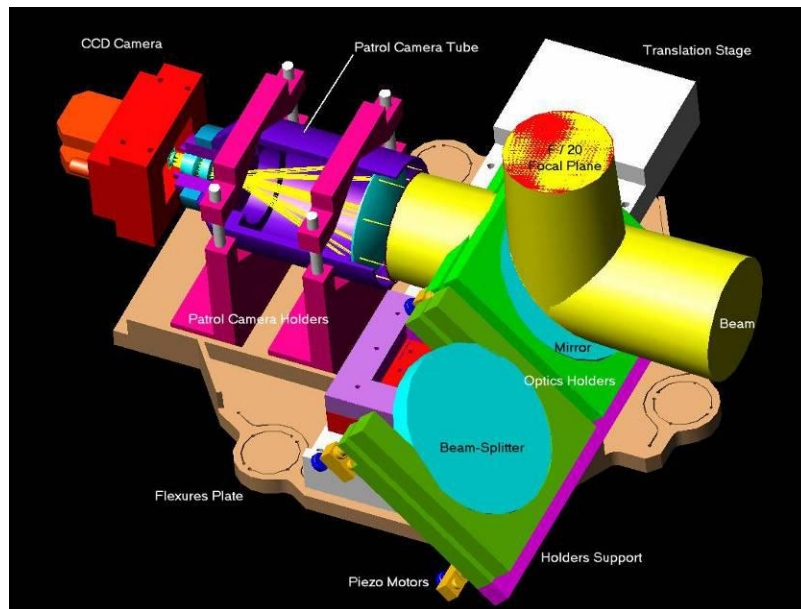

Figure 9: a 3-D view of the patrol camera system

The status of the patrol camera, which is its integration phase in the astronomical observatory of Rome, is that the opto-mechanics is almost completely assembled while the detectors are going to be tested in these days, and the first patrol camera should be delivered by the end of 2006.



Figure 10: The Patrol Camera opto-mechanics mounted in Rome Observatory laboratory

4. CONCLUSIONS

The four Layer Oriented Multiple Field of View wavefront sensors and the two patrol cameras are in their integration phases in the Italian INAF observatories of Padova, Bologna and Rome. Their constructions is carried out in co-operation with the Max-Planck Institute of Heidelberg, where for example the tests on the linear stages have been performed, the tip-tilt stages for the star enlargers alignment have been designed and built and the mechanical drawings of the MHWS have been carried out. The first MHWS wavefront sensor shall be ready by the end of the year, and there is an option to mount a beam splitter on it in order to use, on the same MHWS, the pupil re-imagers (splitting the light with a beam splitter between the two objectives) of the second MHWS, in order to drive in close loop the two DMs which have been already bought in Heidelberg. This mean that, by mid 2007, there might be in Heidelberg a full MCAO system mounted on an optical bench testing a single arm of the final NIRVANA system.

REFERENCES

1. Beckers J. M., "Increasing the size of the isoplanatic patch size with multiconjugate adaptive optics", in *ESO conference on Very Large Telescopes and their instrumentation*, M.-H. Hulrich ed., pp. 693, 1988.
2. Beckers J. M., "Detailed compensation of atmospheric seeing using multiconjugate adaptive optics", *SPIE Proc.* **1114**, pp. 215-217, 1989.
3. Farinato J., Ragazzoni R., Diolaiti E., Vernet-Viard E., Baruffolo A., Arcidiacono C., Ghedina A., Cecconi M., Rossettini P., Tomelleri R., Crimi G., Ghigo M., "Layer oriented adaptive optics: from drawings to metal", *SPIE Proc.* **4839**, pp. 588-599, 2003.
4. Marchetti E., Hubin N., Fedrigo E., Brynnel J., Delabre B., Donaldson R., Franza F., Conan R., Le Louarn M., Cavadore C., Balestra A., Baade D., Lison J.-L., Gilmozzi R., Monnet G., Ragazzoni R., Arcidiacono C., Baruffolo A., Diolaiti E., Farinato J., Viard E., Butler D., Hippler S., Amorim A., "MAD the ESO multi-conjugate adaptive optics demonstrator", *SPIE Proc.* **4839**, pp. 317-328, 2003.
5. Vernet Viard E., Ragazzoni R., Arcidiacono C., Baruffolo A., Diolaiti E., Farinato J., Fedrigo E., Marchetti E., Falomo R., Esposito S., Carbillet M., Verinaud C., 2003, *SPIE Proc.* **4839**, pp. 344
6. Ellerbroek B., Rigaut F., Bauman B., Boyer C., Browne S., Buchroeder R., Catone J. W., Clark P., d'Orgeville C., Gavel D. T., Herriot G., Hunten M. R., James E., Kibblewhite E. J., McKinnie I. T., Murray J. T., Rabaud D., Saddlemeyer L. K., Sebag J., Stillburn J., Telle J. M., Veran J.-P., "Multiconjugate adaptive optics for Gemini-South", *SPIE Proc.* **4839**, pp. 55-66, 2003.

7. Herbst T., Ragazzoni R., Andersen D., Boehnhardt H., Bizenberger P., Eckart A., Gaessler W., Rix H.-W., Rohloff R.-R., Salinari P., Soci R., Straubmeier C., Xu W., "LINC-NIRVANA: a Fizeau beam combiner for the Large Binocular Telescope", *SPIE Proc.* **4838**, pp. 456-465, 2003.
8. Ragazzoni R., "Adaptive optics for giants telescopes: NGS vs. LGS", in *ESO Proceedings of the Bäckaskog Workshop on Extremely large Telescopes* **57**, T. Andersen, A. Ardeberg and R. Gilmozzi, eds., pp. 175-180, 2000.
9. Ragazzoni R., Farinato J. and Marchetti E., "Adaptive optics for 100-m-class telescopes: new challenges require new solutions", *Proc. SPIE* **4007**, pp. 1076-1087, 2000.
10. Ragazzoni R., "Pupil plane wave front sensing with an oscillating prism", *J. of Mod. Opt.* **43**, pp. 289-293, 1996.
11. Ragazzoni R., Farinato J., "Sensitivity of a pyramidal wavefront sensor in closed loop adaptive optics", *A&A* **350**, pp. L23-L26, 1999