

The LINC-NIRVANA Patrol Camera

Dario Lorenzetti^a, Francesco D'Alessio^b, Gianluca Li Causi^a, Fabrizio Vitali^a,
Fernando Pedichini^a, Roberto Speziali^a,
Emiliano Diolaiti^b, Jacopo Farinato^c, Roberto Ragazzoni^c,
Florian Briegel^d, Fulvio De Bonis^d, Wolfgang Gaessler^d and Roberto Soci^d

^aINAF - Osservatorio Astronomico di Roma, via Frascati 33, 00040 Monte Porzio, Italy

^bINAF - Osservatorio Astronomico di Bologna, Via Ranzani 1, 40127 Bologna, Italy

^cINAF - Osservatorio Astrofisico di Arcetri, Largo E.Fermi 5, 50125 Firenze, Italy

^dMax Planck Institut für Astronomie Königstuhl 17, 69117 Heidelberg, Germany

ABSTRACT

LINC-NIRVANA is the IR Fizeau interferometric imager of the Large Binocular Telescope (LBT) in Arizona. Here we describe in particular the design, realization and preliminary tests of the so-called Patrol Camera. It can image (in the range 600-900 nm) the same 2 arcmin FoV seen by the Medium- High-Wavefront Sensor (MHWS), adequately sampled to provide the MHWS star enlargers with the positions of the FoV stars with an accuracy of 0.1 arcsec. To this aim a diffraction-limited performance is not required, while a distortion free focal plane is needed to provide a suitable astrometric output. Two identical systems will be realized, one for each single arm, which corresponds to each single telescope. We give here the details concerning the optical and mechanical design, as well as the CCD and the control system. The interfaces with LINC-NIRVANA are also presented both in terms of matching the carbon fiber optical bench and developing of suitable software procedures. Since the major components have been already gathered, the laboratory tests and the integration are currently in progress.

Keywords: Astronomical Instrumentation – LBT – CCD - Acquisition

1. INTRODUCTION

The Patrol Camera is conceived to assist in field-finding and placement of the wavefront sensor probes. To that scope, it is located next to each MHWS and receives some or none of the visible light, depending on which of the several beam-splitters/mirrors are in place below the MHWS. The major requirements for the Patrol Camera come from the distribution of stars as a function of galactic latitude. LINC-NIRVANA has been designed to supply MCAO correction on $\sim 10\%$ of the sky, i.e. in the neighborhood of the galactic plane and on selected regions. The MHWS can work with a maximum of 8 reference stars, picked by the stars enlargers within a 2 arcmin field. A quick computation, based on the star count model of Bachall & Soneira (1980), reveals that we should always have ~ 30 stars brighter than magnitude 18 within the field of view of the MHWS. To have a rough comparison of the expected targets for MHWS see Table 1: the distribution of stars (up to a given magnitude) is given as a function of the galactic latitude b . Since the model predicts star counts only for $b \gtrsim 20^\circ$, the values in the last column are obtained by adopting a largely conservative extrapolation. Note that $b \sim 6^\circ$ corresponds to 10.3 % of the entire sky.

Taking into account the quantum efficiency, RON, and dark current of the detector, and all the losses through the optical path, our simulations show that an 18th mag star will be acquired with a peak SNR greater than 10, i.e. enough to get a good centroid measurement, even for such faint stars, in a ~ 6 sec of exposure time. All the details are presented in the Final Design Review document (Lorenzetti et al. 2005); here the overall view of the system is shown in Figure 1 (left panel) and its key parameters are summarized in Table 2.

Further author information: (Send correspondence to Dario Lorenzetti)

Dario Lorenzetti: E-mail: dloren@mporzio.astro.it, Telephone: +39 0694286435

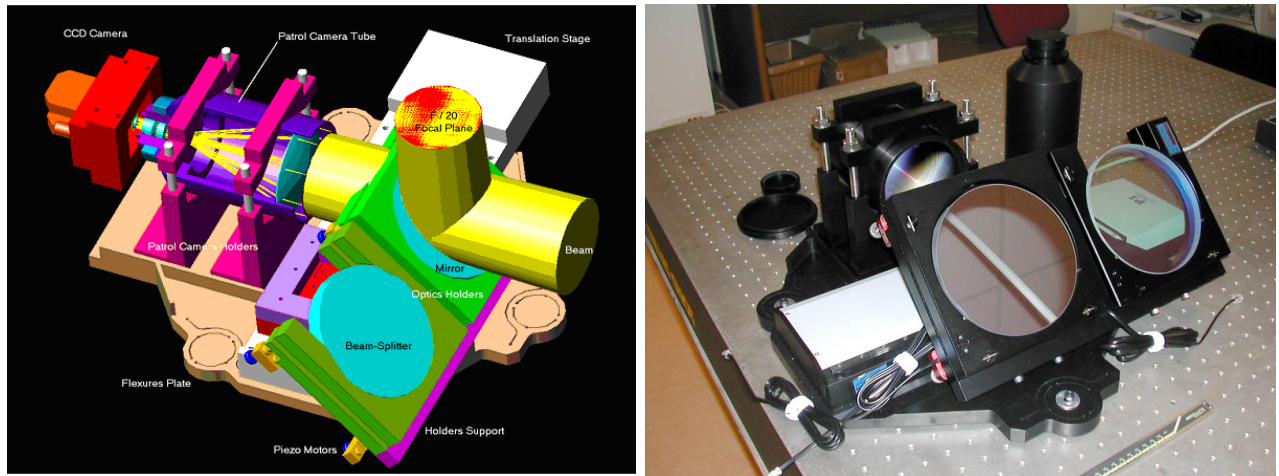

Figure 1. *Left panel:* Overall 3D view of the LN Patrol Camera system. *Right panel:* Preliminary assembly of the opto-mechanical components.

Table 1. Number of stars brighter than a given V mag, located within a circle of 2 arcmin diameter.

V mag	$b=90^\circ$	$b=50^\circ$	$b=20^\circ$	$b=6^\circ$
< 18	0.62	1.80	10.0	30
< 20	1.43	4.85	33.9	90
< 22	2.85	10.3	78.3	240
< 24	4.94	18.3	143	450

2. OPTICAL LAYOUT

The Patrol Camera is essentially a focal reducer, which re-images the central 2 arcmin FoV of the flat and telecentric F/20 focal plane provided by the LINC-NIRVANA optics to fit the useful 13.3×13.3 mm area of a Marconi CCD47-20 (see section 4.1). The focal reduction factor is ~ 9 . Further constraints come from the mechanical layout of the LINC-NIRVANA optical bench, and in particular, from the MWS geometry. As shown in section 3", little room exists between the unfolded F/20 focal plane (placed 150 mm behind the MWS Fold Mirror) and the edge of the optical bench. This fact makes preferable, both from the alignment and the mechanical point of view, a compact optical design rather than longer optics to be folded one or more times. Alternatively, the Patrol Camera could be placed outside the instrument enclosure; obviously this choice forces us to use a higher number of lenses. All these constraints are fulfilled by the Field Acquisition Lens of the Multi Conjugated AO Demonstrator (MAD) on VLT (Delabre 2002); therefore we have adopted the same optical system for the Patrol Camera, with minor refinements concerning the input focal plane distance, the image focal plane position and the insertion of our CCD camera windows. This optical design gives the required optical quality in the wavelength range 600 nm to 900 nm for which the LINC-NIRVANA optical system is optimized.

2.1. Camera Performances

Figure 2 depicts a solid view of the camera optics. The system ends with the CCD window, i.e. the 2.5 mm thick BK7 window of the E2V CCD-Peltier package. The final system is quite compact, having a physical external diameter of about 10cm and a length of about 225 mm from the F/20 to the F/2.22 focal plane. This design reduces the effective focal length to 18611.5 mm, yielding a scale of 11.05 "/mm, or 0.144 "/pixel (13

Table 2. Main parameters of the LN Patrol Camera.

Detector	
CCD	CCD47-20-353 back-illuminated
Pixel size	13 μm square
CCD area	13.3 \times 13.3 mm; 1024 \times 1024 pxl
Full well capacity	5000 e ⁻
Download time	\sim 2 sec
RON (at 2 sec)	\sim 6 e ⁻ pxl ⁻¹
CCD assembly	SciMeasure <i>Little Joe</i>
ADC	16 bit
Cooling	Peltier 40° below ambient
Camera	
Optics type	Focal reducer - 6 elements
Reduction factor	8.98
Effective focal length	18673.7 mm
Effective F/number	F/2.26
Plate scale	\sim 11 mm; \sim 0.14"/pxl
FoV	2 arcmin
Wavelength range	600 to 900 nm
Average spot size	11.6 μm rms
100% Encircled energy diameter	\sim 60 μm ; 0.66"
Optical distortion	< 0.5% for 100% of FoV
Typical exposure time	\sim 5 sec
Predicted stars (S/N>10) in 5 sec	\sim 30

μm pixel size), with a reduction factor of 8.98. The optical design has been adapted to the SILO Test-Plates catalog. It has also been optimized to have best performance in the 600-900 nm wavelength range at a mean working temperature of 5°C (a winter-summer temperature range of -10°C-20°C is assumed). Figure 3 contains the Spot Diagram at 5°C: the average rms spot size is 11.7 μm while the Encircled Energy Diagram (Figure 4) indicates that 100% of the PSF light is enclosed in a diameter of \sim 60 μm , corresponding to \sim 0.66" on the sky.

This PSF, convolved with an expected 0.5"-1.0" uncorrected seeing spot yields \sim 10 \times 10 pixel sampling for each star. This gives a centroid measurement accuracy of 1/5 of a pixel, i.e. 0.03", which is about three times better than required. The optical scheme is also optimized for the optical distortion and presents a residual field distortion lower than 0.5% across the whole FoV (see Figure 5). Our analysis assumes that the wavelength range is already restricted to 600-900 nm before the F/20 focal plane, so that a special anti-reflection coating for this spectral range is applied to each lens surface.

2.2. Thermal and Tolerance Analysis

The thermal analysis shows that the optical quality remains practically unchanged over the temperature range (-10°C to 20°C) without any focus compensation. The possible slight change of image scale due to thermal variations of the LINC-NIRVANA optical path is not a concern, because [x,y]-pairs of stars are required in physical units of the F/20 focal plane and not in sky units, namely in millimeters and not in arcsec.

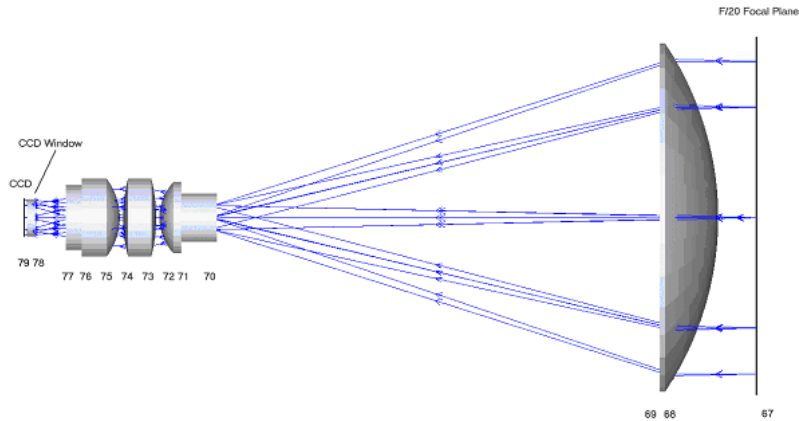

Figure 2. Patrol Camera optical layout. The optical surface numbers are referred in the text.

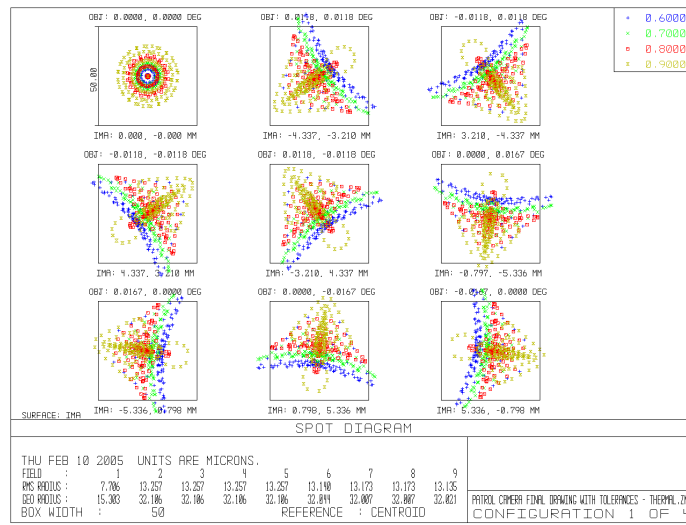

Figure 3. Spot Diagram for the wavelength range 600 to 900 nm at mean working temperature (5°C). The reference boxes are 50×50 μm, approximately 4×4 pixels.

The tolerance analysis has been obtained for a simple optical mount which exploits spacer rings among the three small lens groups. For the optical CCD system as a whole, we obtain very relaxed values for the x/y decentering tolerances, i.e. ±1 mm in order to keep the FoV inside the CCD area, and x/y tilting tolerances of ±0.2°, which yield a variation of only 1 μm in the rms spot radius. Such analysis indicates that we can build a rigid optics-CCD system with no need for adjustment of any element or back focus, where the air thickness between the first lens and the F/20 focal plane (element 67) is used as tolerance compensator during the alignment phase. A second compensator (air space thickness of element 77) has been used in the tolerance computation to compensate our lack of knowledge of the exact distance between last lens and the CCD window. This distance will be measured on the real devices and the mechanical tube will be profiled accordingly before its final mounting.

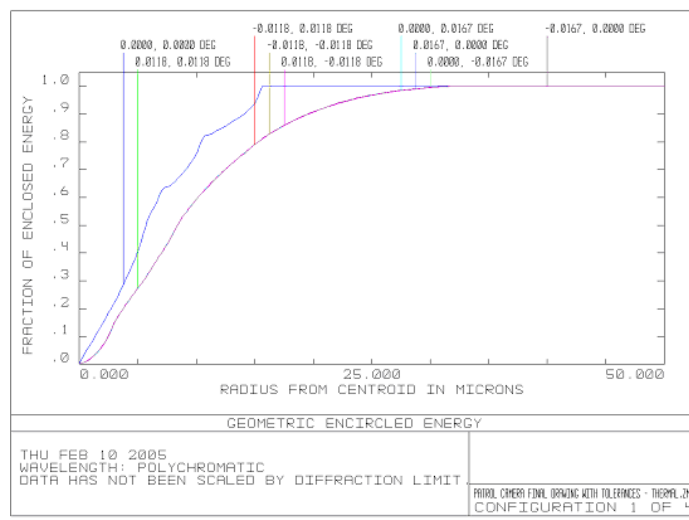

Figure 4. Encircled Energy diagram at the mean working temperature (5°C): all the light is included within a radius of $\sim 30 \mu\text{m}$.

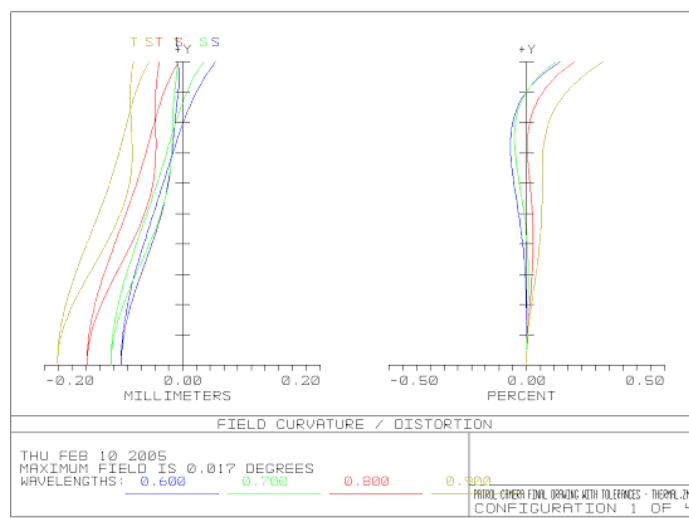

Figure 5. Field Distortion at the Patrol Camera focal plane at the mean working temperature (5°C).

2.3. Folding Mirrors and Beam-splitters

The Patrol Camera will receive the LINC NIRVANA F/20 beam by removing the 45° fold mirror which provides the focal plane to the MHWS star enlargers. This is done by means of a linear translation stage, which places a beam-splitter in place of the mirror, to allow simultaneous functioning of the Patrol Camera and the MHWS (see Section 3). For simplicity, both the fold mirror and the beam-splitter are cut in a circular shape (150 mm diameter) and are mounted on adjustable kinematical holders, whose movements are remotely controlled by a system of small piezo-motors controlled by a paddle. This system allows optical alignment of the F/20 focal plane at the MHWS within the required tolerances. Apart from the coating, both the mirror and beam-splitter have the same characteristics as reported in Table 3. When using the beam-splitter, the optical response analyzed in section 2.1 changes as reported in Figure 6.

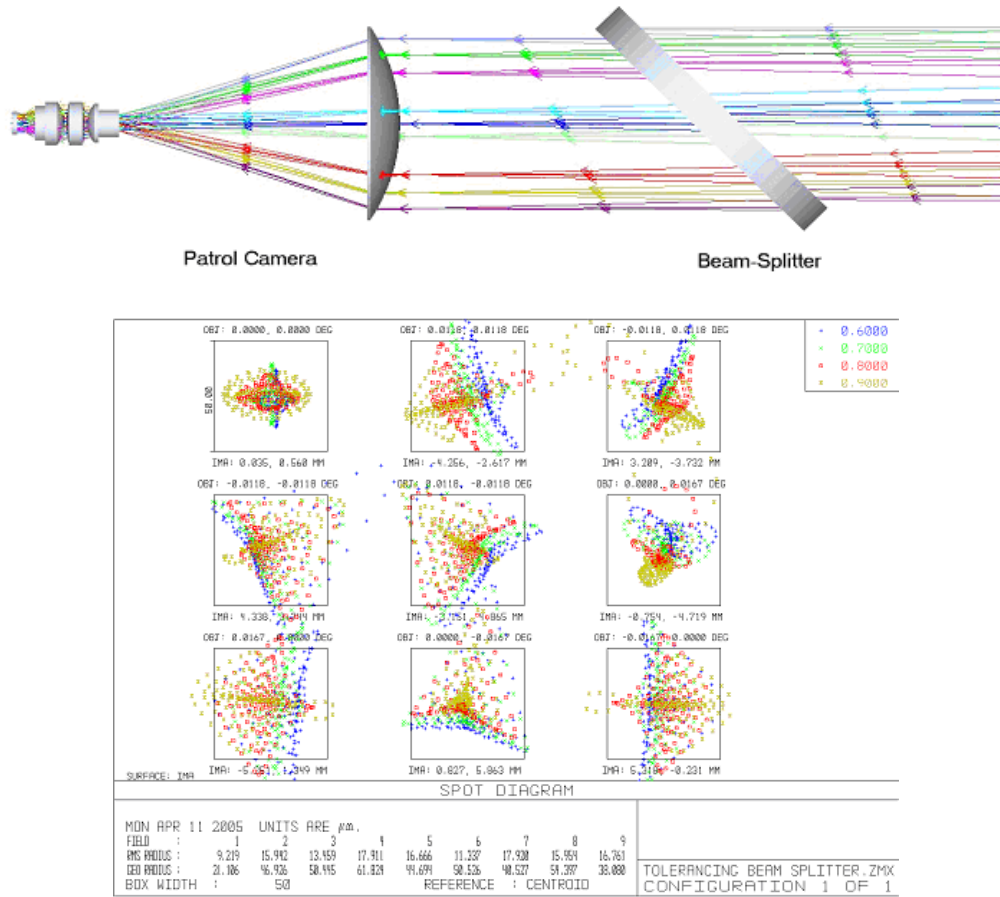

Figure 6. *Top panel:* Optical path through the beam-splitter. *Bottom panel:* The Spot Diagram (at 5°C) after introduction of the beam-splitter.

3. MECHANICAL LAYOUT

The optical and mechanical elements that compose the Patrol Camera Assembly (PCA) are shown in Figure 1. They consist of an interface plate, locked to the LINC-NIRVANA optical bench, holding a motorized linear translation stage, whose aim is to position a mirror or a beam-splitter on demand. These latter elements are accommodated in two adjustable holders with piezo actuators. The plate also supports the Patrol Camera Tube itself, which is joined to the CCD camera. The entire system is placed just below the MHWS tower on the optical bench, in order to match the F/20 focal plane of LINC-NIRVANA. Hereafter, we describe each of these components.

3.1. Translation Stage

The Patrol Camera is directly fed by the optical beam when the mirror is removed. In order to move the mirror, a translation stage is installed under the AO tower. The chosen translation stage is the Physik Instrumente M-521.DG. This device is a zero-backlash recirculating ballscrew device, equipped with a DC motor, limit switches, a high resolution shaft-encoder, and a unique servo amplifier mounted on board which is able to reach a positional accuracy of 1 μm at a speed of 6 mm/s. The maximum travel range is 204 mm and a remotely

Table 3. Specifications for the folding mirror and beam-splitter.

Properties	folding mirror	beam-splitter
Shape	Circular	Circular
Diameter	150 mm	150 mm
Thickness	18 mm	18 mm
X-Y axis tolerance	± 0.1 mm	± 0.1 mm
Z axis tolerance	± 0.1 mm	± 0.1 mm
Tilt tolerance	1.7'	1.7'
Material	Fused silica	Fused silica
Coating	Protected aluminum	80/20% reflect./transm.

controllable brake is available to lock the stage after powering-off. These translation stages will be operated directly by the LINC-NIRVANA motor controller unit, while a PI Mercury II controller is routinely used for laboratory tests.

3.2. Flexures Plate

The positioning tolerances of the Fold Mirror (see Table 3) require that the translation device have a high stiffness, and that its shape and position are completely unaffected by temperature variations. Since the LINC-NIRVANA optical bench is made of carbon fiber, whose thermal expansion is virtually zero, the aluminum base of the stage could be stressed by thermal expansion. Because of the different materials which constitute the translation stage, the firm cannot guarantee the functionality of the actuator under mechanical stresses. We therefore have to interface it to the optical bench using an aluminum plate with suitable flexures which compensate for thermal variations. The realized flexures plate is shown in Figure 7 (left panel);

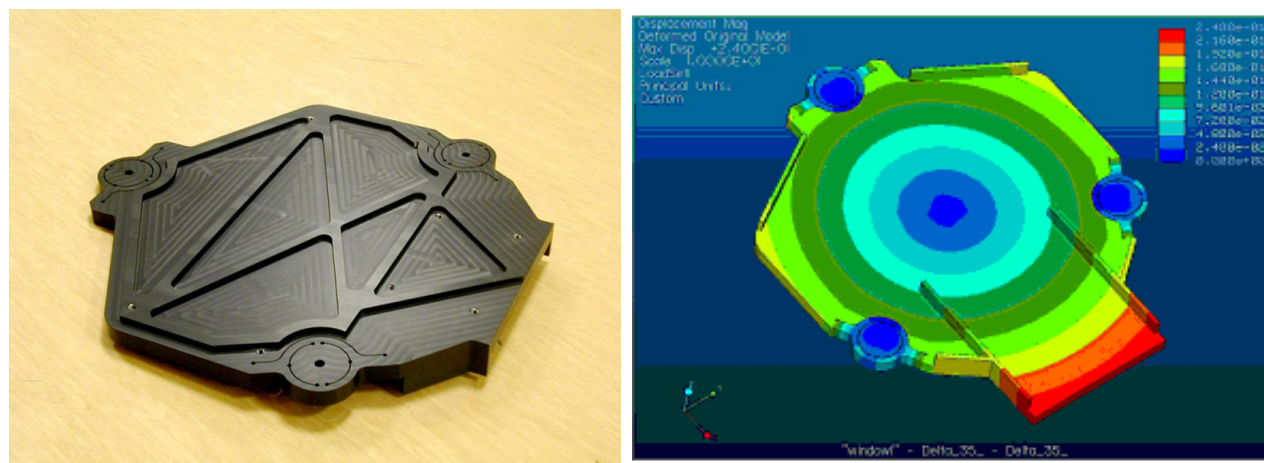

Figure 7. *Left panel:* Bottom view of the plate which shows the flexures and the reinforcements structures. *Right panel:* FEA analysis of the Flexures Plate: residual thermal variation for 35°C temperature change.

This shape has been computed by Finite Element Analysis (FEA) to guarantee the mirror position stability at all working inclinations of the telescope (Figure 7, right panel). The typical thermo-mechanical characteristics of a 2000 series aluminum alloy have been used in this analysis. The plate will be attached at three dedicated

holes on the bench placed in an equilateral triangle pattern with sides of 350 mm. The thickness of the plate is 17 mm, and reinforcements are placed on both side of the plate to increase its stiffness in some critical area, as shown in the figures. The stress analysis shows that, even for 35°C of temperature change, the level of stress in the critical area of the flexures remains below the yield stress of the alloy (Figure 7 right).

3.3. Opto-Mechanical Assembly

The camera optics mounting we have realized is shown in Figure 8, is made of an aluminum tube interfaced with the external mount of the CCD head. The main tube hosts the first and larger lens at one side and a separate mount for the group of small lenses. The CCD camera will be attached to this last mount via an interface flange locked by four M5 screws. This arrangement will give high stiffness, and a FEA analysis allowed us to quantitatively verify that the tolerances are fulfilled. The whole tube is then hold over the flexure plate by two V-shaped supports, which also allow for fine focus adjustment during the set-up.

4. CCD CAMERA

This section describes the camera system. We will show the detector main characteristics and the CCD array selected for the current application. A general overview of the camera system will be presented: the controller, the overall architecture and the data flow. Moreover, the camera cooling system will be briefly described.



Figure 8. Mechanical mounting of the camera optics.

4.1. Detector

We selected the Marconi CCD47 sensor, a 1024×1024 pixels detector with 13 μm square pixels. It is a back illuminated device, and the combination of a low noise amplifier with low dark current (see Table 4) makes it well suited for the current application. E2V offers two different models of CCD47: the 47-10, a standard full-frame 1K×1K array, and the 47-20, a Frame Transfer CCD with an effective surface of 1K×1K. The first model requires a shutter, mounted in front of the array, to select the exposure time. However, placing a shutter within the compact optical design is difficult due to the very short distance between the lenses. Therefore, the 47-20 array has been selected. Moreover, the theoretical exposure time will be typically few seconds, i.e. long enough to ignore the drift scan effect due to the rows scrolling during the readout procedure.

Table 4. Marconi CCD 47-20 Main Characteristics.

Technology	back illuminated
Spectral range	200 – 1100 nm
Nominal resolution	1024 × 1024 pxl
Usable pixels	1024 × 1033 pxl
Image area	13.3 × 13.3 mm ²
Pixel size	13 μm
Active area	100 %
Max Readout frequency	5 MHz
Read-Out Noise	2 e ⁻ rms
Dark Current at 293K	250 e ⁻ /pxl/s
Full Well Capacity	50000 e ⁻

4.2. The camera system

A variety of CCD camera systems are available, i.e. CCD controller for devices as the E2V 47 20. Our selection has been driven mainly by the need to standardize all CCDs working in different segments of LINC-NIRVANA; low read noise and high dynamic range were also considered. The SciMeasure Little Joe digital camera is a system able to fulfill these requirements. This camera system consists of: (i) a camera head, where the sensor is installed and Peltier cooled; (ii) an electronic controller; (iii) a frame grabber, which is located in the camera controller PC. The PC receives the images coming from the controller itself and saves them. The main element of Little Joe is the controller. It is a modular, configurable and programmable electronic device able to manage a wide range of CCD detectors in many modes. In the current application, each controller will be configured in a standard mode to manage one E2V 47-20 CCD array. The controller unit contains a set of dedicated boards:

- The Command Module, the heart of the instrument, which receives commands from the control PC through an RS232 serial port, and manages the other modules and the overall camera operation (array input, array output, etc.).
- The Service Module provides the CCD bias voltages and powers other devices, such as thermoelectric cooler, heaters, and vacuum and temperature sensors. In the current application, this module will control the cooler and will read the three temperature sensors: two on the array and one for the controller itself.
- The Clock Driver Module provides the readout clock signals.
- The Input Module receives the video signals from the camera head and converts them to 16 bit digital data.
- The Output Module sends images to the frame grabber. This link uses the AIA (Automated Imaging Association) protocol. This standard specifies connectors for machine vision, scientific, medical, and general purpose image data acquisition in professional environments. The connectors transfer all power along with analog and digital signals between the camera and an image processor. In the current application, the main purpose is the image downloading. Moreover, the AIA connector incorporates a RS232 serial port which is implemented in Little Joe and it is used to replace the serial link to the Command Module. This option has been adopted for optimizing the camera wiring.

In Figure 9 the camera system is shown along with its electronic controller, while Figure 10 depicts a general overview of the Little Joe system. The images are downloaded through a frame grabber (model: PCI DV made

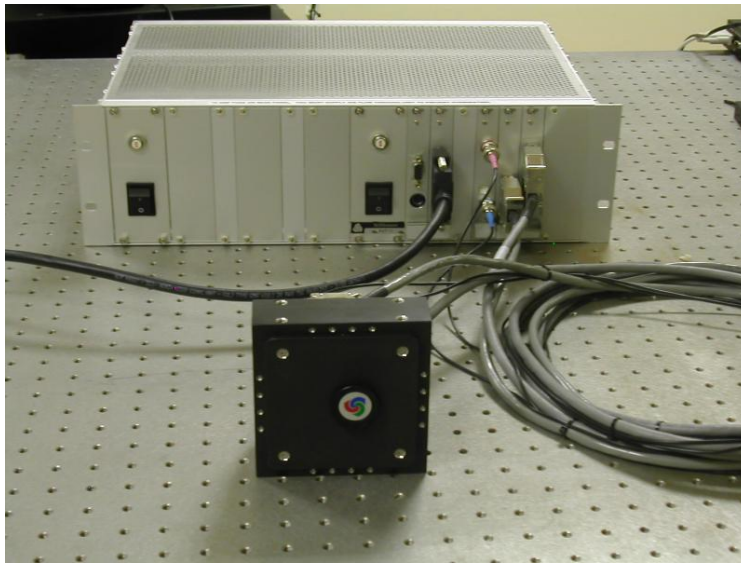

Figure 9. Little Joe system with its electronics.

by Engineering Design Team Inc). It provides high-resolution image capture for digital video cameras and is designed to receive the data flow according to the AIA standard. One of the key requirements of the CCD system is the read-out speed. The goal is to acquire the AO field of view, provide the reference star astrometry, and provide tools to verify the AO efficiency. This demands a high download speed. Downloading is closely related to the readout noise: the noise increases with the readout speed. Little Joe's flexibility allows us to modify the controller setup to select the optimum compromise for a wide range of applications. In particular, the download time requested for the Patrol Camera is ~ 2 seconds/frame. Table 5 reports four typical examples of setups for noise vs readout speed. The data reported in the Table 5 come from SciMeasure and take into account all contributions (controller and CCD) to the readout noise.

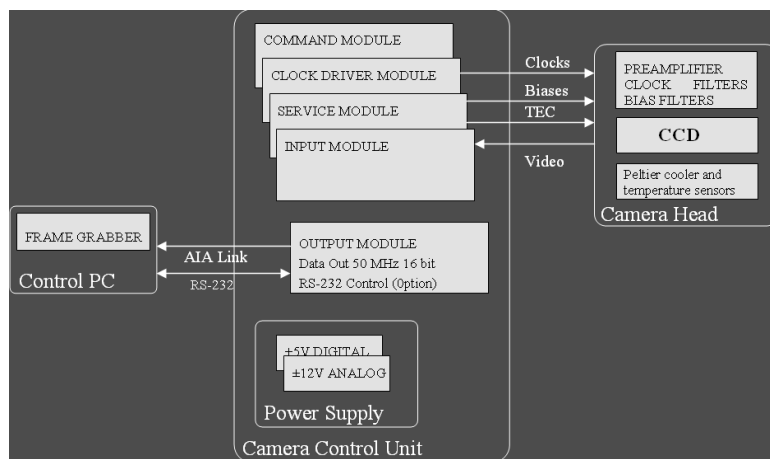

Figure 10. The Little Joe Digital Camera structure.

Table 5. Little Joe performance - Noise vs Pixel Rate.

Noise	Pixel rate	Frame rate
$((e^-/\text{pxl}/s)$	Mpixel/s/channel)	(frame/sec)
3	0.080	6.6
4	0.250	2.1
6.9	1.500	0.35
8.5	2.500	0.21

4.3. Cooling System

The SciMeasure camera system uses a standard E2V cryostat (Figure 9). This package is equipped with a 2-stage Peltier cooler which gives a temperature reduction of approximately 40°C with respect to ambient's. It is hermetically sealed and filled with low conductivity inert gas for dry cooling. Moreover, the system is supplied with an anti-reflection coated window. An internal temperature sensor monitors the array working condition. According to the technical requirements the camera should not produce heat dissipation in the environment close to the LINC-NIRVANA optical path. In order to prevent any thermal dissipation the camera head is equipped with a liquid inter-cooler (Figure 11) fed from the telescope glycol water system.

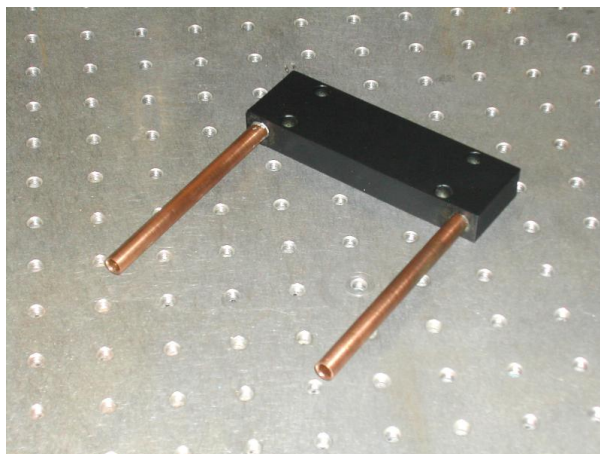

Figure 11. The camera glycol inter-cooler.

5. CONTROL SYSTEM

5.1. Hardware Configuration

As mentioned above, the download speed is one of the crucial features of the CCD camera. The AIA Link is a fast connection able to provide good noise performance. However, this connection requires a cable not longer than 6 m. This constraint forces us to place the control PC close to the CCD cameras: following the LINC-NIRVANA approach, we will use two PCs placed in the two racks located under the optical bench; each controlling one Patrol Camera. This configuration drives the PC choice toward a couple of embedded computers: compact, robust, and able to work in a unconventional environment. The frame grabber and the Patrol Camera software will be installed directly in two of the MHWS reconstructor PCs already planned, in order to optimize the available room and resources. The current application requires the following characteristics for each control PC:

- powerful CPU and high computing speed to allow fast image acquisition and reduction;
- large memory, RAM and HD;
- one Ethernet port to control the Patrol Camera system remotely.

Using a dedicated software, described below, the PC units must execute the following tasks:

- CCD control via RS 232 serial link available in the AIA connector.
- Image download through the frame grabber.
- Image reduction and stellar astrometry.
- Monitor display of the images acquired by the CCD.

5.2. Software Tools

The Patrol Camera Control Software has two main tasks: managing the CCD cameras and computing the astrometry through image reduction and analysis. For the first aim a set of libraries provided by SciMeasure will be adopted to manage the camera operations, while for the second one, a series of dedicated routines will be implemented.

The control software will be written in C++ and will be integrated in the LINC-NIRVANA common software, according to the instrument software infrastructures designed to organize the message exchanging among distributed objects (control software, monitoring procedures, data management, etc.) The CCD control routines include command procedures for sending commands to the Little Joe controller via the serial port, and the download routines which will be designed starting from the PCI DV frame grabber library. After download, the images will be stored in the PC memory mass device to be ready for the next step, namely the data reduction. The images will be read by a set of routines that: (i) automatically find all detectable stars in the field; (ii) compute their centroid positions; (iii) make a quick aperture photometry; (iv) apply a distortion corrective matrix (if needed), due to the Patrol Camera optics; (v) transform the positions into the (x,y) pairs of coordinates, in millimeters, in the LINC-NIRVANA F/20 focal plane.

The SExtractor package (Bertin & Arnouts 1996) will be used for all pre-processing, astrometric and photometric tasks. The final product will be a list containing the star positions, along with their fluxes and a pre-processed FITS image of the field, ready to be used to verify the star enlarger positioning. An additional software task involves image display, which is performed by an external package (e.g. DS9 or GAIA). The Patrol Camera software will allow the operator to require automatic image display at the end of data reduction. In that case, the external package will be directly run by the Patrol Camera software.

REFERENCES

1. Bahcall J.N., Soneira R.M. " The universe at faint magnitudes. I - Models for the galaxy and the predicted star counts", 1980 *ApJSS* 44, 73
2. Bertin E., Arnouts S. " SExtractor: Software for source extraction.", 1996 *A&A Supp* 117, 393
3. Delabre B., 2002 *ESO Tech. Report* OWL-SPE-ESO-60000-0067
4. Lorenzetti D. et al., 2005 *Final Design Review* doc.n.LN-INAFR-FDR-AO-001 Issue 1.2